



## Flat screen wall mount | full motion TH-3270-UFM

Fits most displays from 32" to 65"



Mounting hole pattern:  
from 150mm to 805mm wide  
from 140mm to 500mm high



Maximum weight carrying capacity:  
65kg (143lbs)

The TH-3270-UFM combines cutting edge, sleek design with the capacity to hold a display 65kg (143lbs) in weight out from the wall. Full motion capability comes from three pivot points that give you complete control over tilt, pan, swing, pull out and pivot. Such superior control with minimal effort is thanks to Telehook's Smooth Glide™ technology and spring assisted tilting mechanisms. These innovative features support the full weight of your screen during adjustment, allowing one person to easily set the screen position for maximum viewing comfort. The die cast aluminum arm can extend out to 635mm (25") from the wall and the universal mounting hole pattern ensures this mount is compatible with a vast range of TVs. It comes pre-assembled, with a design that guarantees quick and easy installation. The display can be mounted in either portrait or landscape mode.



### Product key features:

- Sophisticated design and highly durable materials
- Comes pre-assembled to save valuable installation time
- Offers full range of motion for any viewing angle
- Can be mounted either in portrait or landscape orientation
- Spring supported tool less tilt adjustment of 10° up and 20° down
- TV horizontal (levelling) adjustment of 5° either way from the horizontal plane
- Maximum reach from wall 635mm (25")
- Minimum distance from wall 174mm (6.8")
- Advanced cable management
- Comes with all mounting hardware for masonry and timber stud wall installation

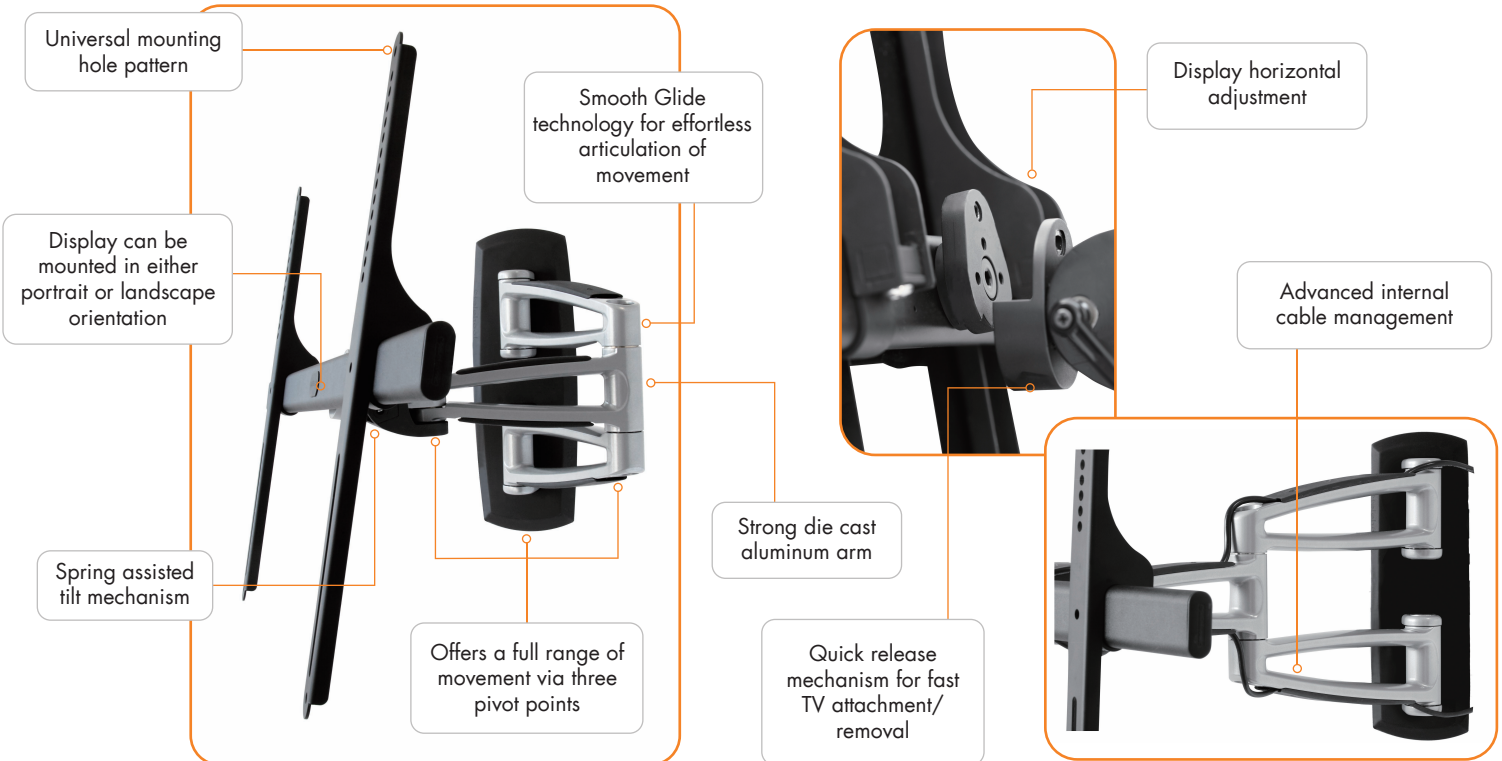

Atdec North America [www.atdec.com](http://www.atdec.com)  
Atdec Global [www.atdec.com.au](http://www.atdec.com.au)

## Product information, single unit

| Load capacity | Material       | Color             |
|---------------|----------------|-------------------|
| 65kg (143lbs) | Aluminum/Steel | Silver with Black |

## Package information, single unit

| Size  | Ship weight       | UPC code     | Contents  |
|---|-------------------|--------------|---|
| 88cm x 43.2cm x 16cm<br>(34.5" x 16.75" x 6.5") | 11.92kg (26.6lbs) | 881493004658 | All hardware required for installation supplied |

## Package information, master pack

| Size  | Ship weight      | UPC          | Units per master pack |
|---|------------------|--------------|-----------------------|
| 90cm x 45cm x 36cm<br>(35.5" x 17.75" x 13.75") | 25.4kg (56.6lbs) | 881493004726 | 2                     |

## Technical drawings

### Side View

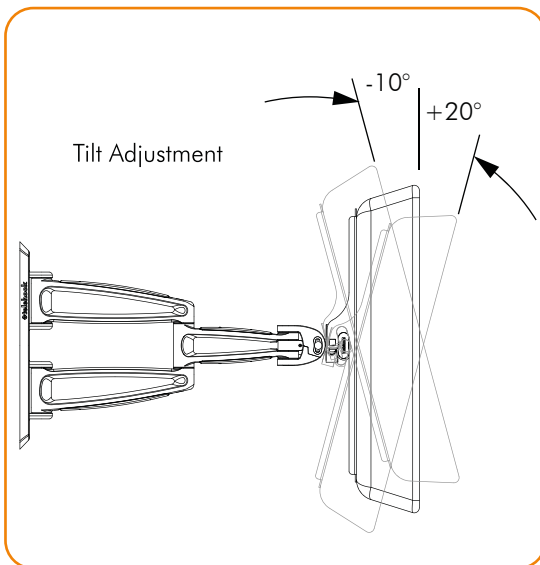

### Articulated Arm Range of Movement

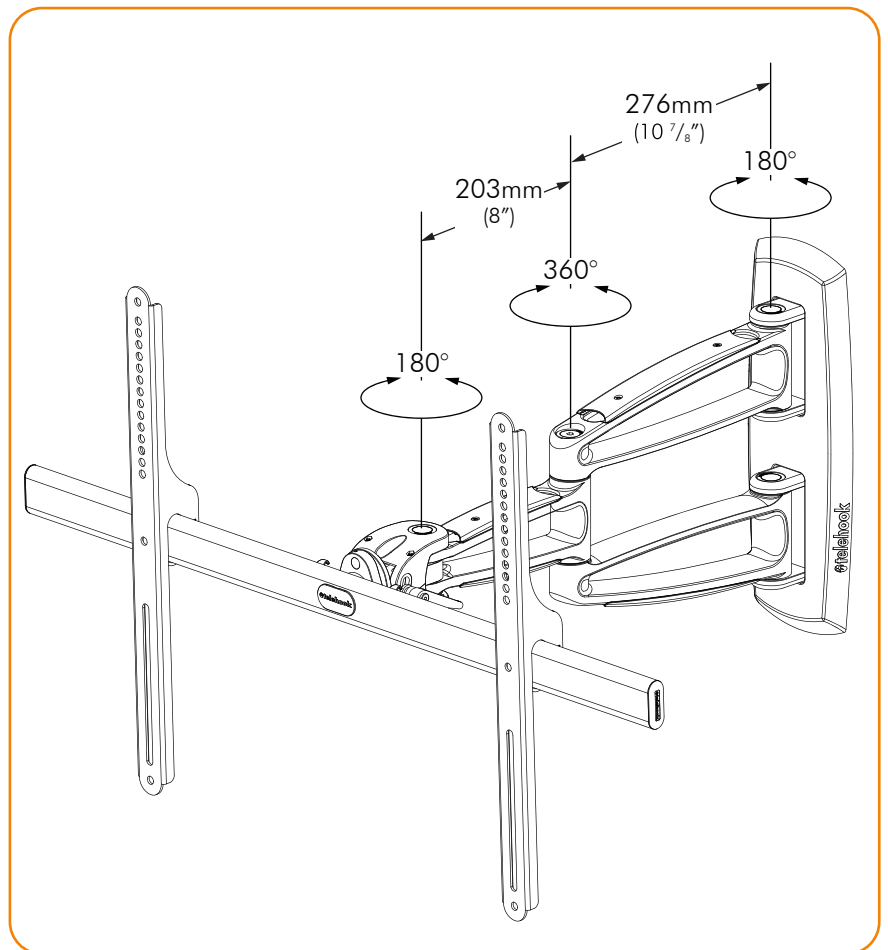

### Distance from Wall

